

- 黒 [MULTI]
- 青 [AES/EBU]
- 黒 [ANALOG]
- 黒 [SYNC]
- ⊕ [V77用デジタルケーブル]

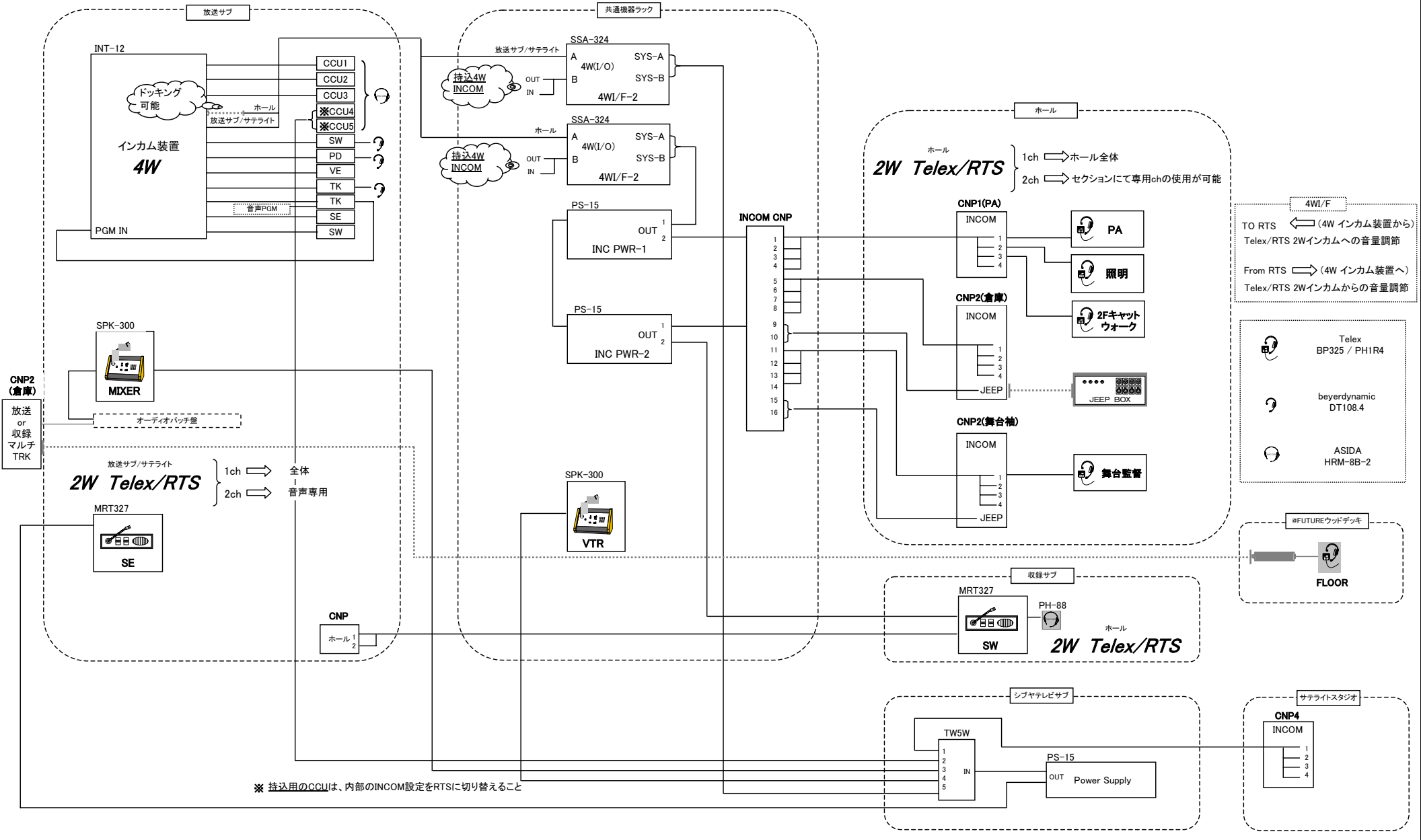

※ 挿入用のCCUは、内部のINCOM設定をRTSに切り替えること

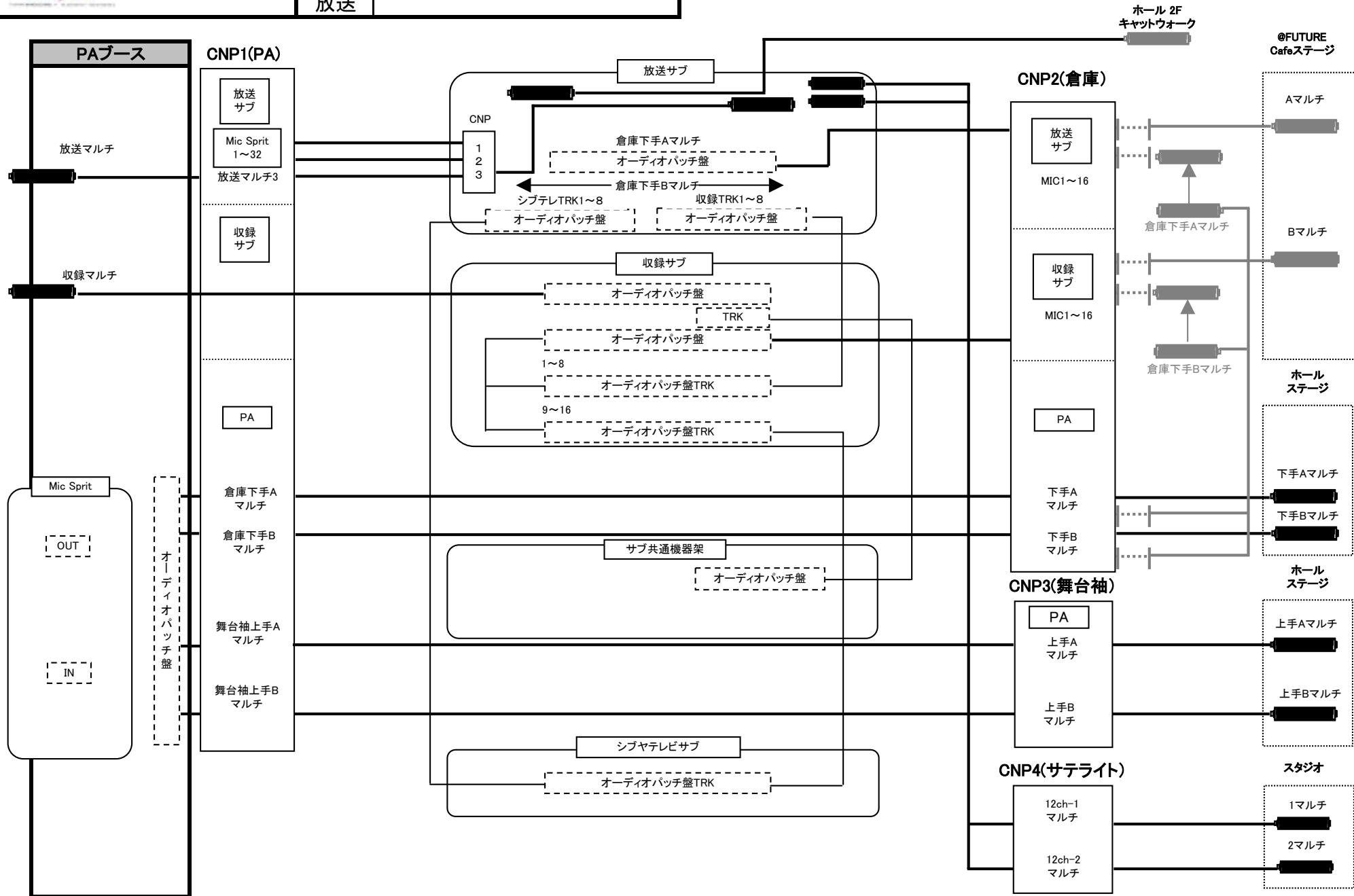

※マルチは16chシステムを採用



ARTIST:		MIX OP:	
番組:		TEL:	
イベント:		FAX:	

DATE:		DIGI MIX[メイン] WR-DA7シート
		BOXX AUDIO DIV.
		e-mail:shibuyaboxx@yahoo.co.jp

No	INSTRUMENT	Mic	ROUTE	AUX SEND	MULTI-BOX
1					
2					
3					
4					
5					
6					
7					
8					
9					
10					
11					
12					
13					
14					
15					
16					
17		FROM O2R BUS 1			
18		FROM O2R BUS 2			
19		FROM O2R BUS 3			
20		FROM O2R BUS 4			

No	INSTRUMENT	Mic	ROUTE	AUX SEND	MULTI-BOX
21		FROM O2R BUS 5			
22		FROM O2R BUS 6			
23	効果卓-L				
24	効果卓-R				
25					
26					
27					
28					
29					
30					
31					
32					
2TR A-L	EXT(AES TRANS) DIGI OUT-5				
2TR A-L	EXT(AES TRANS) DIGI OUT-6				
2TR B-L	HM-DH35000(DVHS) V/U/BS TUNER-L				
2TR B-R	HM-DH35000(DVHS) V/U/BS TUNER-R				

SMPTE & VSYNC(WR-SMPTV) / SERIAL PORT	MEMO
T/C (XLR)	
SMPT E(BNC端子)	BB from共通機器ラック VDA-2⇒V SYNC
WORD CLOCK IN (BNC端子)	
WORD CLOCK OUT (BNC端子)	
SERIAL PORT (RS485/422)	EDIT CONTROLLER⇒1107⇒WR-DA7

GRP・AUX入出力系統 デジタル アナログ	MEMO
GRP1	
GRP2	
GRP3	
GRP4	
GRP5	
GRP6	
GRP7	
GRP8	
AUX SEND 3	
AUX SEND 4	
AUX SEND 5	REV 5 SEND
AUX SEND 6	
INSTRUMENT	MEMO
MASTER OUT-LR (ANA)	ADA
REC OUT-LR (ANA)	効果 MONITOR-SP
REC OUT-LR (DIGI)	VDA
DIGITAL SLOT2(WR-AESSV) 1/2	Mix Digi-β
DIGITAL SLOT2(WR-AESSV) 3/4	Mix Digi-β
DIGITAL SLOT3(WR-AESSV) 5/6	Mix Digi-β
DIGITAL SLOT3(WR-AESSV) 7/8	Master insert
MONITOR AOUT-LR(BAL)TRSフォーン端子	MIX MONITOR-SP
MONITOR BOUT-LR(BAL)TRSフォーン端子	TD MONITOR-SP

